

# **iRobot®** Roomba®

Vacuum Cleaning Robot

5TH GENERATION 

**500 Series**  
Owner's Manual







Dear iRobot Roomba owner,

Welcome to the world of iRobot! As an owner of an iRobot Roomba Vacuum Cleaning Robot, you join a world-wide community of people who enjoy more free time. Roomba cleans routinely, so you don't have to. Now you can spend your time on more enjoyable and important tasks.

The Roomba 500 series is the 5th generation of our award-winning iRobot Roomba Vacuum Cleaning Robot. In developing this newest version, we incorporated feedback and suggestions from Roomba owners across the globe to make this robot more efficient and easier to use than its predecessors.

Many advancements are made to our products based on suggestions and feedback from home robot owners like you. To share your feedback, stories or ask questions about your new home robot, please visit our Service and Support site at [www.irobot.com](http://www.irobot.com).

We encourage you to register your robot, either online or by mail. As a registered home robot owner, you'll receive information and updates personalized to your robot and you can save helpful tips and product information in your account. To register online, go to [www.irobot.com](http://www.irobot.com).

Thank you for joining the iRobot community. We look forward to your valued input as we continue to deliver groundbreaking products to change and improve your world.

On behalf of the entire iRobot team,



A handwritten signature in black ink, appearing to read "Colin Angle".

Colin Angle  
Co-Founder and CEO  
iRobot Corporation

# Important Tips

- ⚠ Before using Roomba the first time, you need to activate Roomba by removing the battery pull tab. You should also charge the battery overnight for best results.**

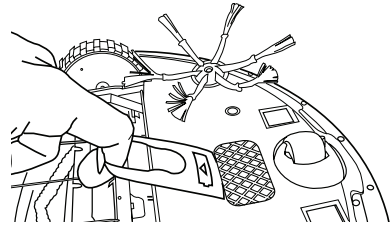

Remove battery pull tab

## Turning Roomba on and off

- Roomba does not have a power button.
- To turn Roomba ON, press CLEAN once. You will hear a beep and the CLEAN button will light.
- To start a cleaning cycle, press CLEAN again. Roomba will start a cleaning cycle.
- To pause Roomba, press CLEAN while Roomba is cleaning.
- To resume the cleaning cycle, press CLEAN again.
- To turn Roomba OFF, press and hold the CLEAN button until Roomba's lights turn OFF.

## For Best Performance

- Remove and clean Roomba's brushes after every use.
- Empty Roomba's bin and clean its filter after every use.
- Use the Virtual Walls® or Virtual Wall® Lighthouses™ to keep Roomba cleaning where you want it.
- Use your Roomba frequently.

## Battery Life

- To extend the battery life, iRobot recommends always storing Roomba plugged in.

## Voice Demonstration

- Roomba® features a voice demonstration to walk you through using Roomba.
- To start the voice demonstration, make sure the CLEAN light is illuminated and then press and hold the DOCK/DEMO button. On model 510, press and release "demo."
- To exit the voice demonstration, press and hold the CLEAN button until the robot shuts down.

- ⚠ Roomba contains electronic parts. DO NOT submerge Roomba or spray it with water. Clean with a dry cloth only.**

# Table of Contents

iRobot Roomba Anatomy.....	6
Cleaning Pattern.....	7
Cleaning System .....	8
Cleaning Modes .....	9
Battery Storage and Charging.....	10 - 11
Virtual Walls® .....	12
Virtual Wall® Lighthouses™.....	13 - 15
Scheduling Roomba .....	16 - 17
Home Base® .....	18
Wireless Command Center.....	19
Maintenance.....	20 - 22
Troubleshooting.....	23
Frequently Asked Questions .....	24
Replaceable Modules .....	25
iRobot Customer Care .....	26
Important Safety Instructions .....	27

# iRobot Roomba Anatomy

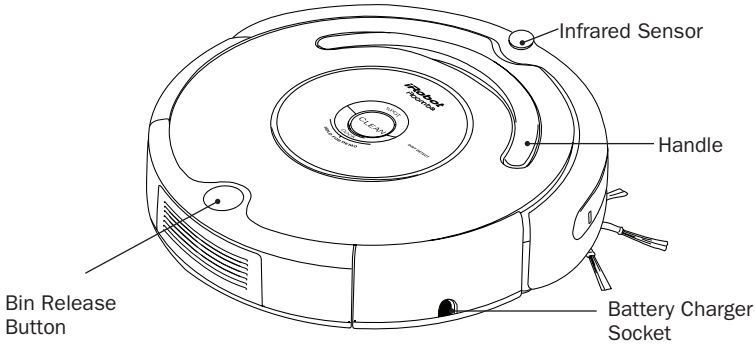

## Buttons and Lights (Models 510 - 545)

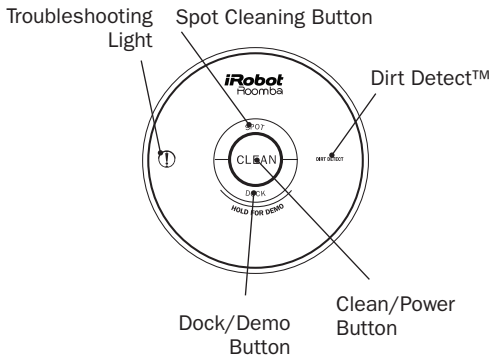

## Buttons and Lights (Models 550 and above)

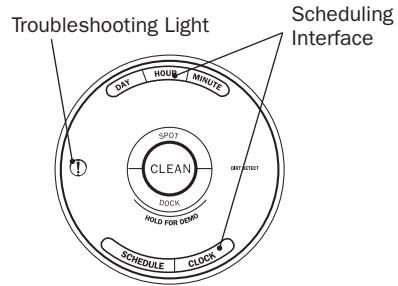

## Bottom View

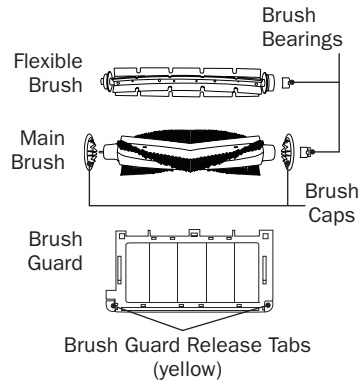
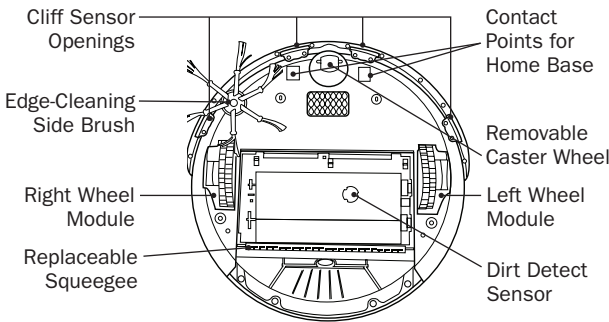

# Cleaning Pattern

Roomba is a robot that cleans floors differently than the way most people clean their floors. Roomba uses its robot intelligence to efficiently clean the whole floor, under and around furniture and along walls.

**Roomba calculates the optimal cleaning path as it cleans and determines when to use its various cleaning behaviors:**

**Spiraling:** Roomba uses a spiral motion to clean a concentrated area.

**Wall Following:** Roomba uses this technique to clean the full perimeter of the room and navigate around furniture and obstacles.

**Room Crossing:** Roomba crisscrosses the room to ensure full cleaning coverage.

**Dirt Detection:** When Roomba senses dirt, the blue Dirt Detect™ light is lit and Roomba cleans more intensely in that area.

**Cleaning Modes:** While cleaning, Roomba automatically calculates the room size and adjusts its cleaning time appropriately.

**Spot Mode:** Roomba will spiral approximately 3 feet in diameter and then spiral back to where it started, intensely cleaning a localized area.

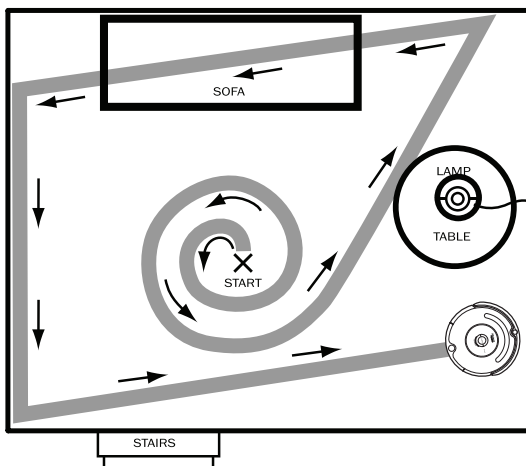

**TIP: Roomba takes approximately 35 minutes to clean an average room and will pass over the same area of the floor multiple times to ensure total floor coverage.**

**TIP: For most efficient cleaning, clear your floor of clutter and use a Virtual Wall to confine Roomba to one room.**

# Cleaning System

Roomba features a patented three-stage cleaning system.

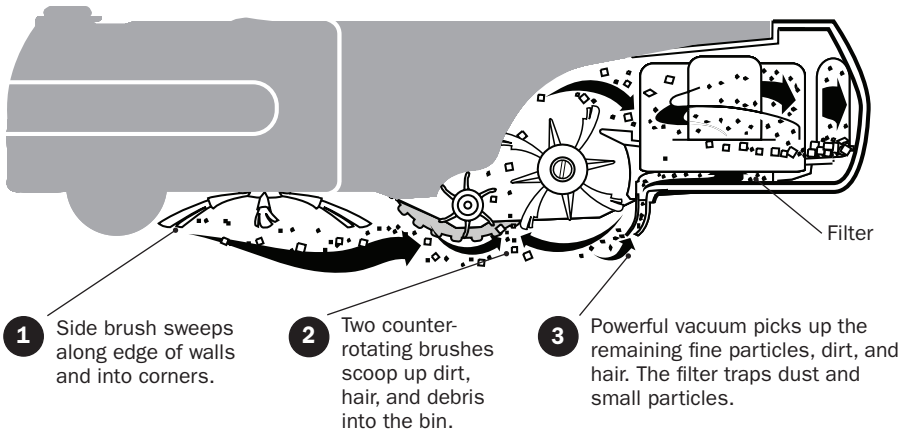

## Floor Surfaces

Roomba works on wood, carpet, tile, vinyl, and linoleum, and adjusts automatically to different floor types.

Roomba automatically senses stairs and other cliffs. Roomba might stall when confronting rounded edges and might slide over particularly slippery surfaces. Extremely dark-colored floors may contribute to Roomba's sensors working less effectively.

## Anti-tangle system

Roomba won't get stuck on cords, carpet fringe or tassels. When Roomba senses it has picked up a cord or tassel, it will automatically stop its main brushes or side brush and try to escape. Roomba may make a clicking noise when anti-tangle is activated.



# Cleaning Modes

Roomba will clean based on the cleaning mode you select. Roomba has three cleaning modes.

## **Clean Mode (all models)**

Roomba automatically calculates the room size and adjusts its cleaning time appropriately.

## **Spot Mode (all models)**

Roomba will spiral approximately three feet in diameter and then spiral back to where it started, intensely cleaning a localized area.

## **Scheduled Cleaning Mode** (Models 550 and above)

When a future cleaning time is programmed, Roomba enters Scheduled Cleaning Mode. When scheduled to clean, Roomba will occasionally flash its next cleaning time to remind you of its schedule. At the specified time, Roomba leaves its Home Base, cleans, and then returns to the Home Base to recharge when it's done.

# Battery Storage and Charging

Roomba is powered by a rechargeable battery. Roomba's battery can last for hundreds of cleaning cycles before a replacement is necessary.

## Battery Life

To extend the battery life, iRobot recommends always storing Roomba plugged in. For more details on how to maintain Roomba's battery life, visit [www.irobot.com](http://www.irobot.com).

**Tip: If Roomba's battery is warm, Roomba will wait for the battery to cool down before beginning a charge cycle.**

**Tip: For long-term storage, iRobot recommends that the battery be fully charged and then removed from the robot and stored in a cool, dry place.**

## Cleaning Time

You should fully charge Roomba's battery before each cleaning cycle. When fully charged, Roomba's battery will last for at least one full clean cycle.

## 16-Hour Refresh Charge

If Roomba has been left off the Home Base/charger for an extended period, Roomba will initiate a special 16-hour charge cycle. This extensive charge refreshes Roomba's battery and extends the battery life. While charging, Roomba's Clean light button will pulse quickly. Note: For best results, do not interrupt this Refresh Charge.

**TIP: For best performance, charge Roomba's battery overnight before using Roomba for the first time. Always leave the battery inside Roomba with Roomba plugged in or on the Home Base.**

## Charging Roomba

Charge Roomba in one of two ways:

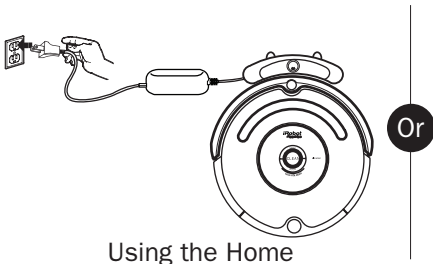

Using the Home Base

Or

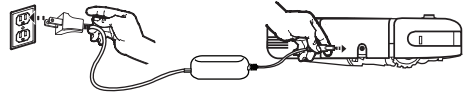

Using the Power Supply Only

**TIP: When Roomba is on the Home Base, always make sure that the Home Base Power and Docked lights are on.**

Roomba uses the “Clean” button light to indicate that it is charging. Use this chart to determine the status of the battery:

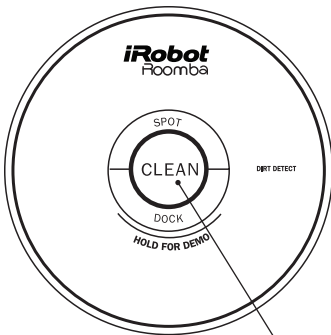

Clean Button Light

Clean button light	What it means
Red	Battery empty
Amber pulsing	Charging
Green solid	Fully charged
Amber flashing	16-hour refresh charge

## Virtual Walls® (included with Models 510 - 530)

The iRobot Roomba Virtual Walls create an invisible barrier that Roomba will not cross. This invisible barrier can be used to confine Roomba to a particular room or area, and prevent it from getting too close to electrical or computer cords, delicate objects on the floor, etc.

The Virtual Walls can be set to block an area up to eight feet long or longer, in three-step increments: 0-3 ft., 4-7 ft., 8+ ft. Note that the width of the Virtual Walls' beam also increases as its length increases, creating a cone-shaped area which Roomba cannot pass. The Virtual Wall also creates a halo of protection around itself, preventing Roomba from getting too close.

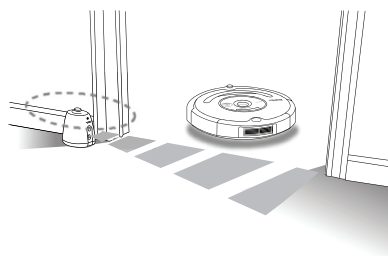

### Battery Installation

The Virtual Wall requires two “D” alkaline batteries and automatically shuts off after 135 minutes. If the power light blinks green, the batteries will soon need to be replaced.

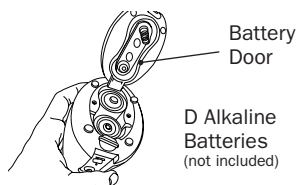

### Range Adjustment

Use the slider bar to adjust the length of the barrier. A longer range will drain the battery faster.

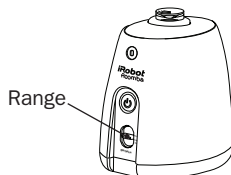

**TIP: Point the iRobot Roomba logo on the Virtual Wall towards the area you would like to block.**

**TIP: For best performance, place the Virtual Wall on the outside of the doorway you wish to block. Set the Virtual Wall to the shortest setting possible to extend the Virtual Wall battery life.**

Additional Virtual Walls may be purchased at **[www.irobot.com](http://www.irobot.com)**.

Virtual Walls are compatible with all 500 Series Roomba vacuuming robots.

# Virtual Wall Lighthouses™ (Models 535 and above)

Virtual Wall Lighthouses can be switched between Lighthouse mode and Virtual Wall mode.

- In Lighthouse mode they help Roomba navigate around your home, find the Home Base, and allow Roomba to clean one room before starting the next.
- In Virtual Wall mode, they keep Roomba cleaning where you want and out of off-limit areas.

**TIP: Virtual Wall Lighthouses turn on and off automatically as Roomba is turned on or off. When they are on, a light will illuminate on the top of the Virtual Wall Lighthouse. To conserve their battery life, remove the batteries if you are not planning on using the Virtual Wall Lighthouse when cleaning.**

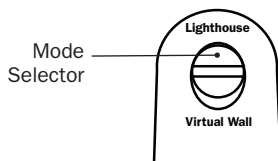

Use the Mode Selector to set the Virtual Wall Lighthouse to Virtual Wall or Lighthouse mode.

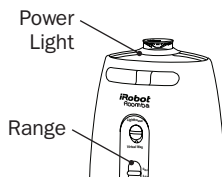
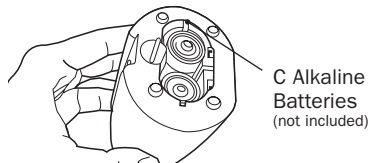

Virtual Wall Lighthouses indicate that their batteries will soon need to be replaced by flashing the power light repeatedly.

# Virtual Wall Lighthouses™ (Models 535 and above)

## Lighthouse Mode

In Lighthouse mode, the Virtual Wall Lighthouse helps Roomba navigate around your home and allows Roomba to clean room-to-room.

Place a Lighthouse in the doorway between to rooms with the iRobot Roomba logo facing forward. Roomba will clean the room it starts in, navigate to the next room, and then clean the second room. When Roomba has completed cleaning, it will use the Lighthouse to navigate back to the Home Base.

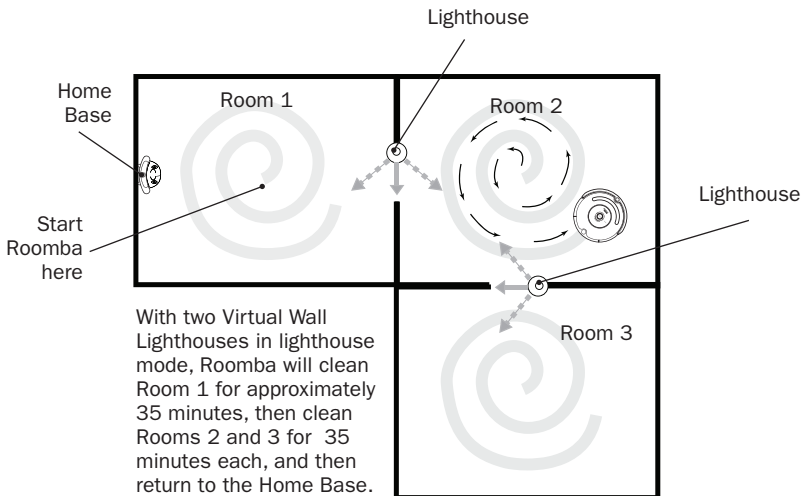
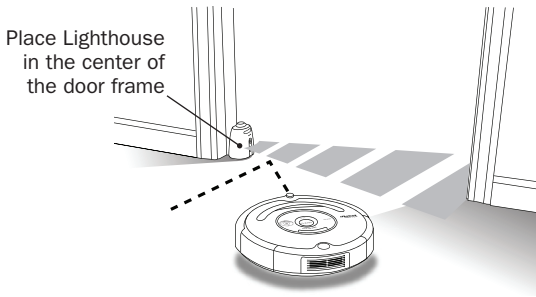

# Virtual Wall Lighthouses™ (Models 535 and above)

## Virtual Wall Mode

In Virtual Wall mode, the Lighthouse creates an invisible barrier that Roomba will not cross.

Use the slider bar to adjust the length of the barrier. A longer range will drain the battery faster.

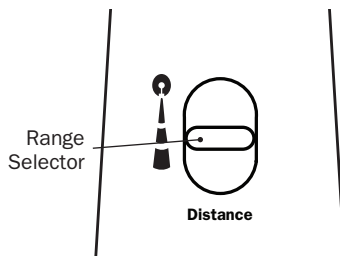

In Virtual Wall mode, the Lighthouse blocks an area up to eight feet or longer, in three-step increments: 0-3 ft., 4-7 ft., 8+ ft. A small halo prevents Roomba from bumping into the Lighthouse and a larger cone-shaped area blocks off areas of your home where you don't want Roomba to go.

**TIP: Use Virtual Wall Lighthouses in Virtual Wall mode to block doorways or to keep Roomba out of off-limit areas.**

**TIP: In Virtual Wall mode, iRobot recommends setting up the Virtual Wall Lighthouse behind the door jamb as shown on pg. 12.**

**TIP: Don't manually move Roomba while it is cleaning. Avoid placing Lighthouses or Virtual Walls too close to each other, the Home Base or furniture that could block the beams. Doing so could prevent Roomba from recognizing the Lighthouses or returning to the Home Base.**

Additional Virtual Wall Lighthouses may be purchased at [www.irobot.com](http://www.irobot.com).

Virtual Wall Lighthouses are compatible with Models 535 and above.

# Scheduling Roomba (Models 550 and above)

## Setting the Time

You must set the time before scheduling Roomba to clean.

- 1 Press and hold **CLOCK**.
- 2 While holding **CLOCK**, use the **DAY**, **HOURL**, and **MINUTE** buttons to set the correct time.
- 3 Release **CLOCK**. Roomba will beep to indicate that the time has been set.

## Setting a Schedule

You can schedule Roomba to clean once per day, up to seven times per week. You must set the time before setting a schedule.

To set a schedule:

- 1 Press and hold **SCHEDULE**.
- 2 While holding **SCHEDULE**, use the **DAY**, **HOURL**, and **MINUTE** buttons to set the schedule.
- 3 Release **SCHEDULE**. Roomba will beep to indicate that the schedule has been set.

## Viewing and Deleting Schedules

To view Roomba's scheduled cleaning times:

- 1 Press and hold **SCHEDULE**.
- 2 While holding **SCHEDULE**, press the **DAY** button to cycle through Roomba's scheduled cleaning times.
- 3 Release **SCHEDULE**.



---

## To Delete a Schedule

- 1 Press and hold **SCHEDULE**.
  - 2 While holding **SCHEDULE**, press the **DAY** button to cycle through Roomba's scheduled cleaning times.
  - 3 When Roomba is displaying the scheduled cleaning time you'd like to delete, press and hold **DAY** to delete the scheduled cleaning time. Roomba will beep to indicate the schedule has been deleted.
  - 4 Release **SCHEDULE**.
- 

## To Change a Schedule

- 1 Press and hold **SCHEDULE**.
  - 2 While holding **SCHEDULE**, press the **DAY** button to cycle through Roomba's scheduled cleaning times.
  - 3 When Roomba is displaying the scheduled cleaning time you'd like to change, press the **HOURL** and **MINUTE** buttons to change the scheduled cleaning time.
  - 4 Release **SCHEDULE**. Roomba will beep to confirm that the schedule has been changed.
- 

Models 535 and above may also be scheduled with the Wireless Command Center (sold separately).

# Home Base®

Roomba returns to the Home Base at the end of a cleaning cycle or when its battery is running low. Roomba needs to find the infrared signal of the Home Base in order to return.

Always keep the Home Base plugged in. When Roomba is on the Home Base, the Power and Docked lights will be green to indicate Roomba is charging.

## Home Base Location

You should position the Home Base on a hard level surface and in an area where Roomba has a clear path to return at the end of a cleaning cycle. Locate the Home Base against a wall or other immovable object to prevent it from sliding during docking. If Roomba is unable to dock on its first attempt, it will try again until it docks successfully.

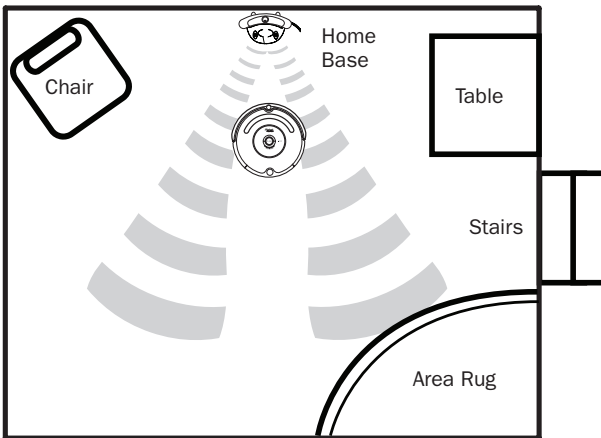

To have Roomba look for the Home Base and recharge its battery, simply press the “Dock” button.

# Wireless Command Center

The Wireless Command Center is compatible with Models 535 and above only. It is included with Models 570 and above, and is otherwise available as an accessory.

The Wireless Command Center lets you conveniently control Roomba's functions. You can use it to turn Roomba on and off, schedule Roomba to clean, and steer Roomba around your room.

To schedule Roomba to clean, use the buttons on the Wireless Command Center as if they were on the robot itself. See page 16 for details on setting Roomba's clock and setting, changing and deleting schedules.

Troubleshooting Indicator

Battery Indicator

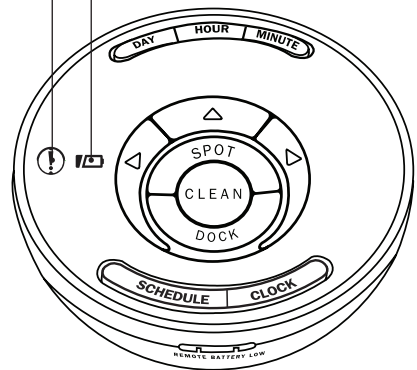

**TIP: When powered on, the lights on the Wireless Command Center will sequence from Sunday to Saturday until the robot is under its control.**

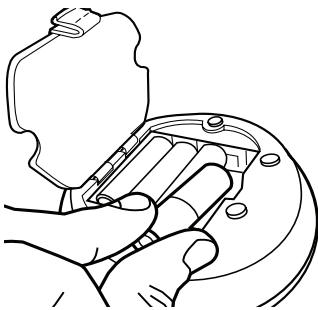

Before using your Wireless Command Center for the first time, install four AA alkaline batteries.

All Command Centers are setup to control only one Roomba. To pair a wireless command center with a robot, first install new batteries while holding down the left turn button, the lights will flash in a sequence from Saturday to Sunday. Second, place the Command Center directly on top of the robot you would like to pair it with and hold the "Day" and "Minute" buttons until the robot flashes and beeps once. The robot and Command Center are now paired.

# Maintenance

To keep Roomba running at peak performance, it is recommended that you perform the following maintenance regularly:

- 1 Remove and empty Roomba's bin after each use

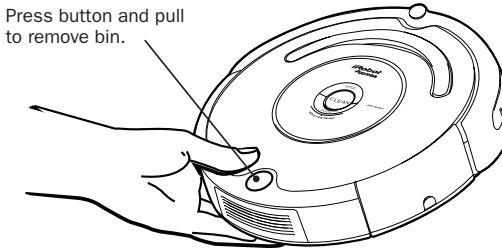

- 2 Clean Roomba's filter compartment

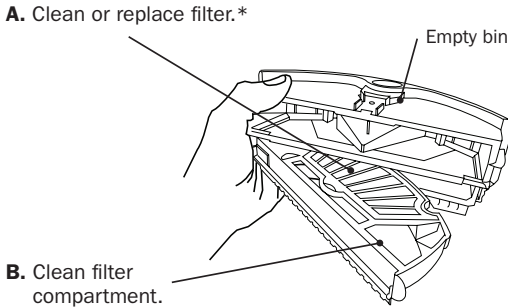

*\*Replace filter every 2 months*

Visit [www.irobot.com](http://www.irobot.com) for information on keeping Roomba running at peak performance.

**TIP: Bin emptying and brush cleaning should be done after every cleaning cycle. Also be sure to regularly check the front caster wheel for hair build up.**

**TIP: If you notice Roomba picking up less debris from your floor, empty the bin and clean the brushes.**

### 3 Clean Roomba's brushes

**A.** Remove brush guard by lifting both yellow tabs.

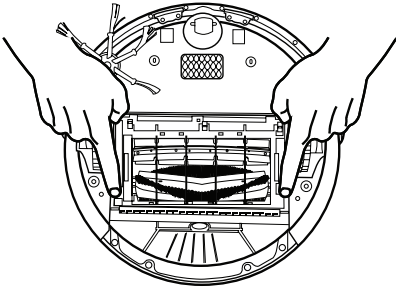

**B.** Remove brush caps and use scissors to cut any hair wrapped around the brush.

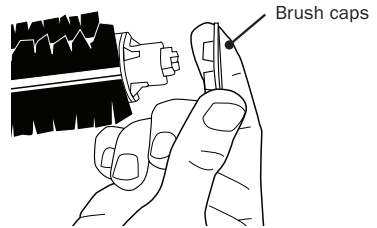

**TIP:** When maintaining Roomba, look for the yellow parts. These parts are designed to be removed and cleaned every time you empty Roomba's bin.

**C.** Remove and clean hair and dirt from Roomba's yellow brush bearings.

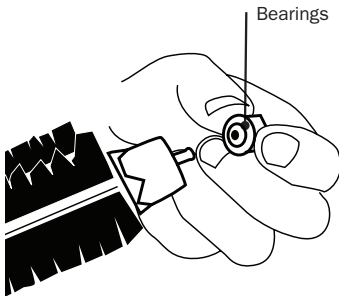

**D.** Use the included cleaning tool to easily remove hair from Roomba's brushes.

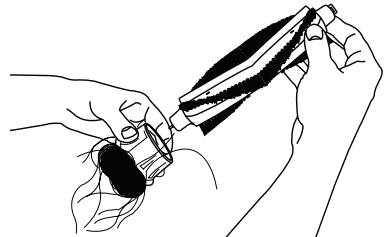

**⚠** Excessive build up of hair in Roomba's brushes and bearings can permanently damage Roomba. Inspect brush bearings regularly.

**⚠** Do not attempt to run Roomba without the bearings. If you misplace Roomba's brush bearings, contact iRobot Customer Care for replacement bearings.

## Clean Roomba's front wheel

- 1** Pull firmly on Roomba's front wheel to remove it from the robot.
- 2** Remove debris from inside the front wheel cavity.
- 3** Remove the front wheel from its housing and clear any hair wrapped around the axle. Push firmly on the wheel axle to remove it completely from the wheel.

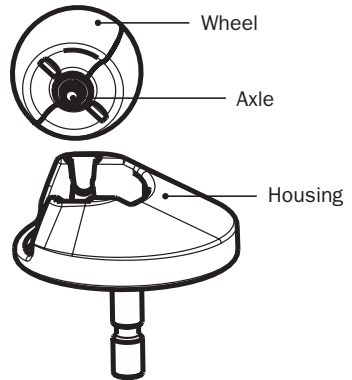

- 4** Wipe the wheel clean.
- 5** Re-install the wheel into the housing, and the module into the robot.

## Clean Roomba's cliff sensors.

- 1** Wipe all four cliff sensors with a clean, dry cloth.

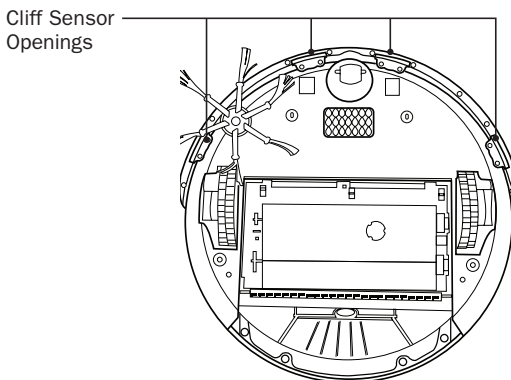

# Troubleshooting

Roomba will tell you something is wrong with a two-tone “uh-oh” sound **\*followed by\*** a series of beeps and, for some issues, a narrated voice.

Refer to the table below to resolve Roomba’s problem.

If the problem is not resolved, visit [www.irobot.com/support](http://www.irobot.com/support).

Roomba beeps....	Likely cause	What to do
1 beep	Roomba is stuck with a wheel hanging down.	Move the robot, ensure all wheels are firmly on the floor and restart the robot.
2 beeps	The main brushes cannot turn.	Remove and clean Roomba’s brushes. See page 21.
5 beeps	A drive wheel is stuck.	Clean Roomba’s drive wheels of hair and debris. Push them in and out and confirm that they both turn freely.
6 beeps	Roomba’s cliff sensors are dirty or Roomba is stuck hanging over a cliff.	Wipe off Roomba’s cliff sensors with a dry cloth and start Roomba in a new location. See page 22.
7 beeps	A drive wheel is stuck.	Clean Roomba’s drive wheels of hair and debris. Push them in and out and confirm that they both turn freely. Start the robot in a new location.
8 beeps	The front wheel is stuck or the robot is stuck.	Remove and clean hair and debris from Roomba’s front wheel. Start the robot in a new location. See page 22.
9 beeps	The robot is stuck with its bumper pressed in or the bumper sensor is dirty.	Inspect and clean Roomba’s bumper.
11 beeps	Roomba’s bumper is not registering obstacles. Roomba may be stuck in one place.	Roomba may be in an extremely large room, try setting up Virtual Walls to create a smaller area. If Roomba is not in a large room, tap Roomba’s bumper to confirm it is properly working.
12 beeps	A cliff sensor is dirty or broken.	Inspect and clean Roomba’s cliff sensors. See page 22.
Roomba says...	Likely cause	What to do
Remove and clean Roomba’s brushes	The main brushes cannot turn.	Remove and clean Roomba’s brushes. See page 21.
Clean Roomba’s cliff sensors	Roomba’s cliff sensors are dirty or the robot is being started over a cliff.	Wipe off Roomba’s cliff sensors with a dry cloth. Ensure the robot is being started with all wheels firmly on the floor. See page 22.
Inspect and clean Roomba’s wheel(s)	A drive wheel is stuck or Roomba’s drive wheels are not touching the ground.	Clean Roomba’s drive wheels of hair and debris. Push them in and out and confirm that they both turn freely. Ensure that the robot is being started with all wheels firmly on the floor.
Roomba blinks...	Likely cause	What to do
1 blink (when charging)	The battery is not connected.	Confirm that Roomba’s battery pull-tab is removed. Remove the bottom cover of Roomba and remove and re-install Roomba’s battery.
2 blinks		Try charging the robot again. If the problem persists, contact iRobot Customer Support
3 blinks		Try charging the robot again. If the problem persists, contact iRobot Customer Support
5 blinks	Roomba has a charging error.	Reset your robot by holding down “Spot” and “Dock” for 10 seconds. Contact iRobot Customer Support if this does not resolve the problem.
6 blinks	Roomba’s battery is too warm.	Let the battery cool down and try charging the robot again.
7 blinks	Roomba’s battery will not cool down.	Let Roomba cool down for at least one hour and try charging again. If the problem persists, contact iRobot Customer Support.

**TIP: To reset Roomba’s software, hold down the spot and dock/demo buttons for 12 seconds. This will clear all scheduled cleaning times, reset the clock and may resolve some software issues.**

## Frequently Asked Questions

### **Why does Roomba's Side Brush occasionally spin backwards?**

When caught on items such as carpet tassels or wires, the Side Brush may spin slowly or briefly spin backwards to free itself. This may also occur on thick or high-pile carpets. If this behavior should occur on hard floor surfaces or when no tassels or wires are present, the Side Brush should be cleaned. Using a small Philips head screwdriver, first remove the screw from the center of the Side Brush. Next remove the Side Brush and thoroughly clean any hair or debris that is wrapped around the shaft. Then reinstall the Side Brush and Side Brush screw.

### **Why does Roomba occasionally make a thumping sound?**

When Roomba's brushes encounter items such as carpet tassels or wires, the brushes will briefly reverse direction to get free. This action causes a thumping sound that can be heard approximately once per second until the brushes are free from obstruction. If Roomba makes a thumping sound when no tassels or wires are present, the main brushes should be cleaned as described on page 21.

### **Why doesn't Roomba slow down as it approaches certain obstacles?**

Roomba uses its Light Touch Bumper technology to identify walls and other obstacles, allowing it to slow down and gently touch the obstacle with its bumper before changing direction. Roomba may be less effective at sensing and slowing down for extremely dark or black surfaces, or for objects that are less than two inches wide.

**TIP:** For additional assistance, visit [www.irobot.com/support](http://www.irobot.com/support).



# Replaceable Modules

Roomba has a number of modules that can be replaced, including its drive wheels, side brush, main cleaning head, vacuum bin, caster wheel, and battery.

To access Roomba's replaceable modules, remove the bottom cover of Roomba by removing the four screws that hold down the bottom cover and the screw that holds the spinning side brush.

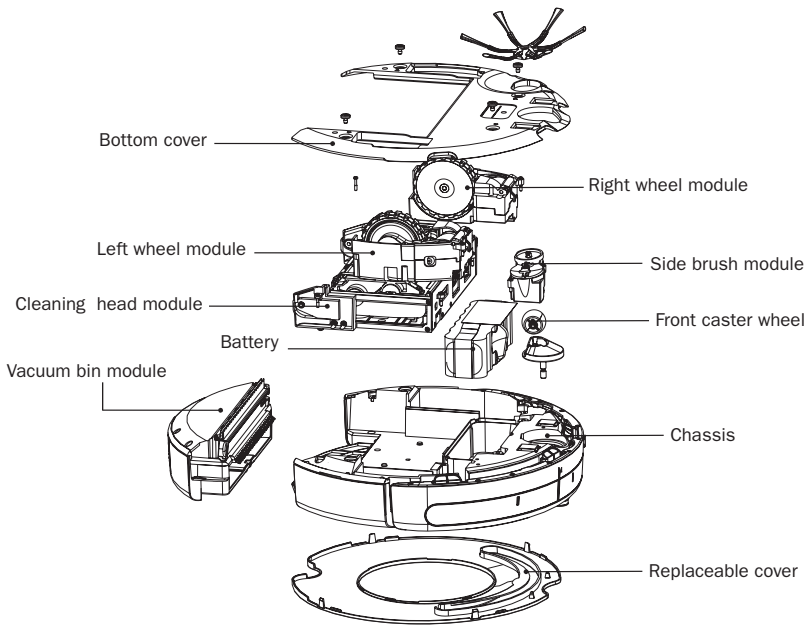

# iRobot Customer Care

If you have questions or comments about Roomba, please contact iRobot before contacting a retailer.

Please visit our web site at **www.irobot.com** for support tips, frequently asked questions, or information about accessories and other iRobot products. We would like to hear from you.

Should you still need assistance:

- Visit the iRobot support web site at **www.irobot.com/support**
- Call our customer care representatives at **877.855.8593**

## **iRobot Customer Care Hours:**

- Monday – Friday 9AM – 7PM Eastern Time
- Saturday 9AM – 6PM Eastern Time

# Important Safety Instructions

**⚠ CAUTION: DO NOT EXPOSE THE ELECTRONICS OF ROOMBA, ITS BATTERY OR THE CHARGER. THERE ARE NO USER-SERVICEABLE PARTS INSIDE. REFER SERVICING TO QUALIFIED SERVICE PERSONNEL. CHARGE USING STANDARD U.S. (120V AC) OUTLET ONLY.**

Always exercise caution when operating your Roomba. To reduce the risk of injury or damage, keep these safety precautions in mind when setting up, using and maintaining your Roomba:

## GENERAL SAFETY INSTRUCTIONS

- Read all safety and operating instructions before operating Roomba.
- Retain the safety and operating instructions for future reference.
- Heed all warnings on Roomba, battery, charger and in owner's manual.
- Follow all operating and use instructions.
- Refer all non-routine servicing to iRobot.

## ROOMBA USE RESTRICTIONS

- Roomba is for indoor use only.
- Roomba is not a toy. Do not sit or stand on this device. Small children and pets should be supervised when Roomba is cleaning.
- Clean with a dry cloth only. Do not pour or spray water onto Roomba.
- Do not use this device to pick up anything that is burning or smoking.
- Do not use this device to pick up spills of bleach, paint, or other chemicals, or anything wet.
- Before using this device, pick up objects like clothing, loose papers, pull cords for blinds or curtains, power cords, and any fragile objects. If the device passes over a power cord and drags it, there is a chance an object could tumble off a table or shelf.
- If the room to be cleaned contains a balcony, a physical barrier should be used to prevent access to the balcony and ensure safe operation.
- Always remove the battery before long-term storage or transportation.

## ROOMBA BATTERY AND CHARGING

- Charge using a standard U.S. (120V AC) outlet only. Product may not be used with any type of power converter. Use of other power converters will immediately void the warranty.
- Use only the charger supplied by the manufacturer to charge this device.
- Do not use a charger with a damaged cord or plug.
- Charge indoors only.
- Roomba's power supply may be protected with a surge protector in the event of severe electrical storms.
- Never handle chargers with wet hands.
- Always disconnect Roomba from the charger before cleaning.

Get iRobot accessories at:  
**800.727.9077** or visit **store.irobot.com**

*\*See registration card for details. Pricing and availability subject to change. Shipping and handling not included.*

---

**iRobot**<sup>®</sup>

© 2007 iRobot Corporation, 63 South Avenue, Burlington, MA 01803. All rights reserved.

iRobot, Virtual Wall and Roomba are registered trademarks of iRobot Corporation. Home Base, Dirt Detect and Lighthouse are trademarks of iRobot Corporation.

U.S. Pat. Nos. 6,594,844; 6,690,134; 6,883,201; 6,809,490; 6,956,348; 7,155,308; 7,173,391.  
Other patents pending.